

SSC-N22/N22A

Analog Color Mini-Dome Cameras

SONY
make.believe

540 TV Line Security Camera with High Sensitivity

- Horizontal resolution 540 TV lines
- High sensitivity
Color : 0.15 lx (F1.2, 50 IRE)
B/W : 0.01 lx (F1.2, 50 IRE)
- x3.7 Variable focal lens
- Compact design



KEY FEATURES

- High resolution (540 horizontal TV lines) and high sensitivity (Color : 0.15 lx / B/W : 0.01 lx, F1.2, 50IRE) achieved by a 1/3-type "Super HAD CCD II" sensor and Sony's new digital signal processor, "Effio-E".

Super HAD CCD II™

- 3.7x variable focal length lens with a focal length of 2.8 mm to 10.5 mm and a horizontal angle of view of 101.8 ° to 27.4 °.
- Easy and flexible camera angle adjustment achieved by a new three-hinge structure.

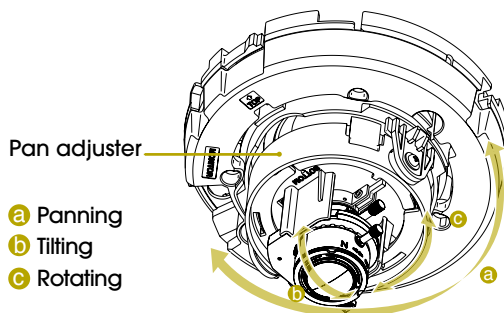

- ATR-Lite (Adaptive Tone Reproduction Lite) to compensate for gradation of subjects to an optimum level.
 - iBLC to compensate for exposure levels in dark scenes to improve subject visibility.
 - ATW (Automatic Tracing White) balance which automatically adjusts the camera's white balance to adapt to sudden changes in lighting conditions.
 - Internal lock, and line lock selectable.
 - 2D noise reduction employed.
 - AC 24 V/DC 12 V operation ($\pm 10\%$).
 - Custom template supplied.
- Optical Day / Night function to switch to Day or Night mode depending on the light level.
 - Low power consumption: 1.7 W (Max.).

SPECIFICATIONS

	SSC-N22	SSC-N22A
Camera		
Image device	1/3-Type "Super HAD CCD II"	
Number of effective pixels (H x V)	440,000 pixels (752 x 582)	380,000 pixels (768 x 494)
Signal system	PAL standard	NTSC standard
Horizontal resolution	540 TV lines	
S/N ratio	More than 55 dB(AGC Off)	
Minimum illumination	Color: 0.15 lx, B/W: 0.01 lx (F1.2, 50 IRE) Color: 0.08 lx, B/W: 0.003 lx (F1.2, 30 IRE)	
Video output	VBS: 1.0Vp-p	
Synchronization	Internal/AC line lock selectable	
Gain control	Auto (on/off)	
White balance	ATW (2000K to 10000K), ATW-PRO (2500K to 6000K)	
Lens type	Built-in variable focal lens	
Zoom ratio	Optical 3.7X	
Horizontal viewing angle	101.8 degree to 27.4 degree	
Focal length	f=2.8 to 10.5 mm	
F Number	F1.2(Wide end), F2.6(Tele end)	
Minimum object distance	300 mm	
Iris	Auto	
Panning range	355 degree	
Tilting range	±77 degree	
Swivel rotation	350 degree	
Camera Features		
Day/Night	Yes	
Noise reduction	Yes (2D NR)	
Back light compensation	Yes (iBLC)	
Automatic tone reproduction	Yes (ATR-Lite)	
General		
Mass	320 g (11.3 oz)	
Dimensions	ø121.6 mm x 86.5 mm (ø 4 7/8 x 3 1/2 inches)	
Power requirement	AC24 V ±10%, DC12 V ±10%	
Power consumption	Max. 1.7 W	
Operating temperature	-10°C to +50°C (14F° to 122F°)	
Storage temperature	-40 °C to +60 °C (-40F° to +140F°)	
Operating humidity	20 % to 80 %	
Storage humidity	20 % to 95 %	
Supplied accessories	Template x 1, Operating instructions x 1	

DIMENSIONS

Unit: mm (inches)

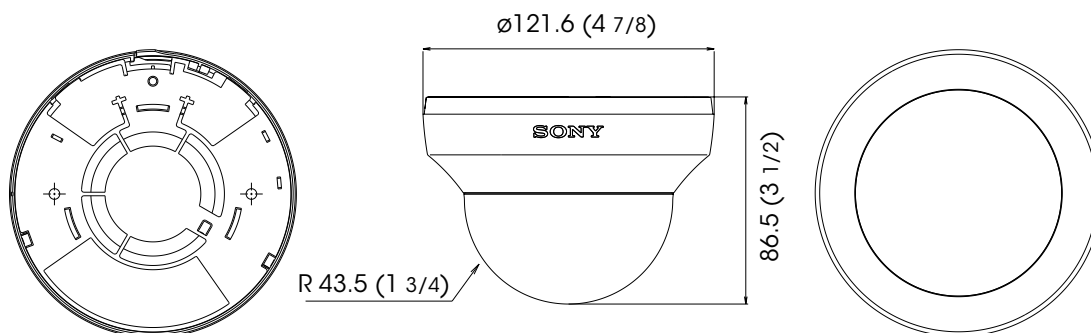

Distributed by

© 2011 Sony Corporation. All rights reserved.
 Reproduction in whole or in part without written permission is prohibited.
 Features and specifications are subject to change without notice.
 The values for weight and dimension are approximate.
 "SONY", "make.believe", "Effio-E", and
 "Super HAD CCD II" are trademarks of Sony Corporation.
 All other trademarks are the property of their respective owners.